

LOC		DIST		P		F		ZONE		LTR		REVISIONS		DATE	APPD	
CM	53												K	REV PER EC 063B-0114-02	19-MAR-02	KW

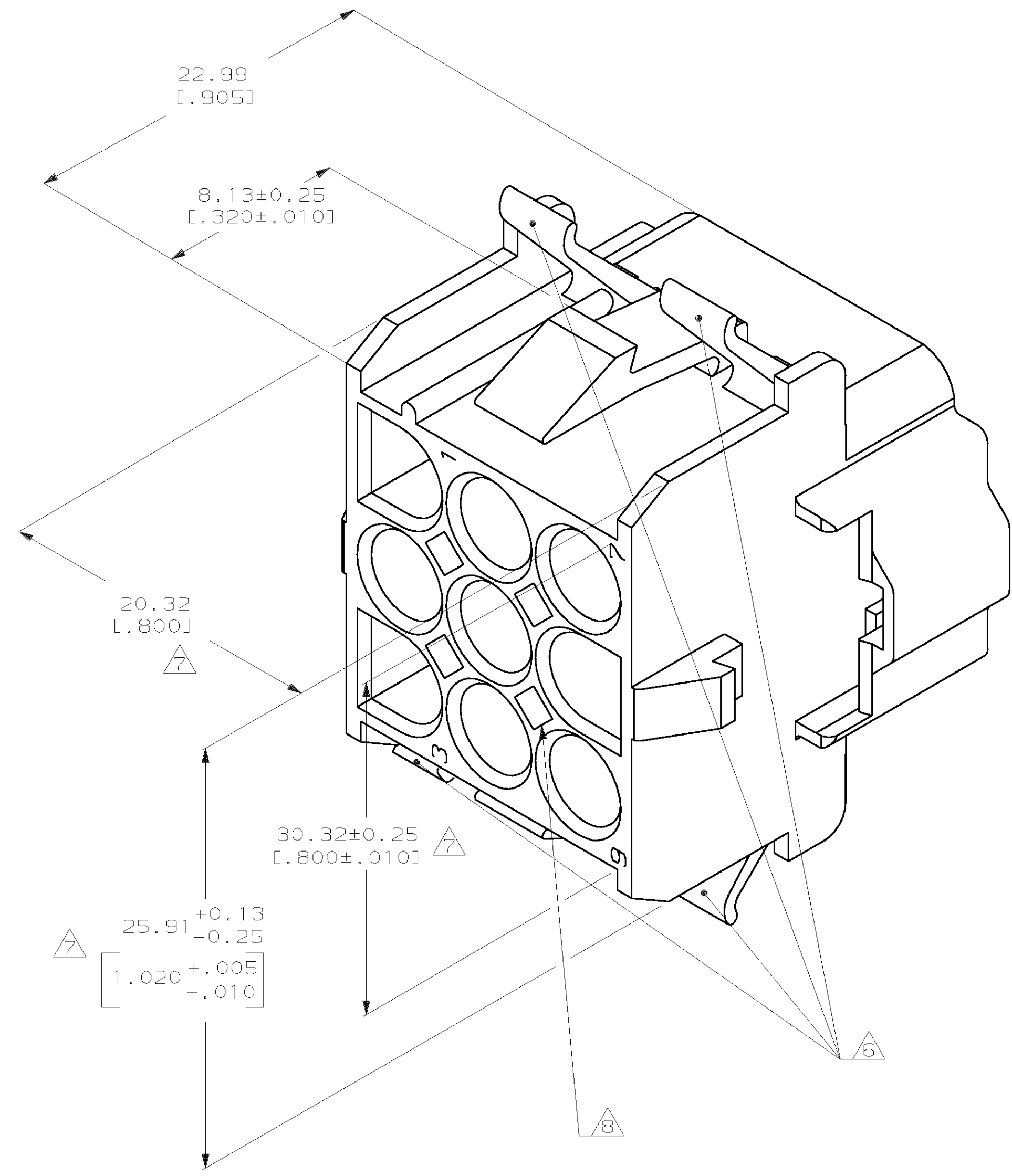

- MUST BE ASSEMBLED WITH CAP REAR P/N 770054-1 BEFORE MATING. KIT P/N IS 770028-1.
- RECOMMENDED PANEL THICKNESS 0.76-2.29 [.030-.090].
- PANEL MUST BE PUNCHED SO THAT THE HOUSING ENTERS THE PANEL IN THE SAME DIRECTION AS THE PUNCH.
- OPTIONAL FOR KEYING HOUSING IN PANEL.
- CIRCUIT NUMBER 1 LOCATION.
- AMP LOGO LOCATED ONCE ON ANY INDICATED SURFACE FARSIDE.
- DIMENSION INDICATED IS AS MOLDED. ADDITIONAL GROWTH DUE TO SUBSEQUENT MOISTURE ABSORPTION MAY OCCUR.
- OPTIONAL CONSTRUCTION PROVIDES ROUND MATERIAL REDUCTION CORING HOLES.

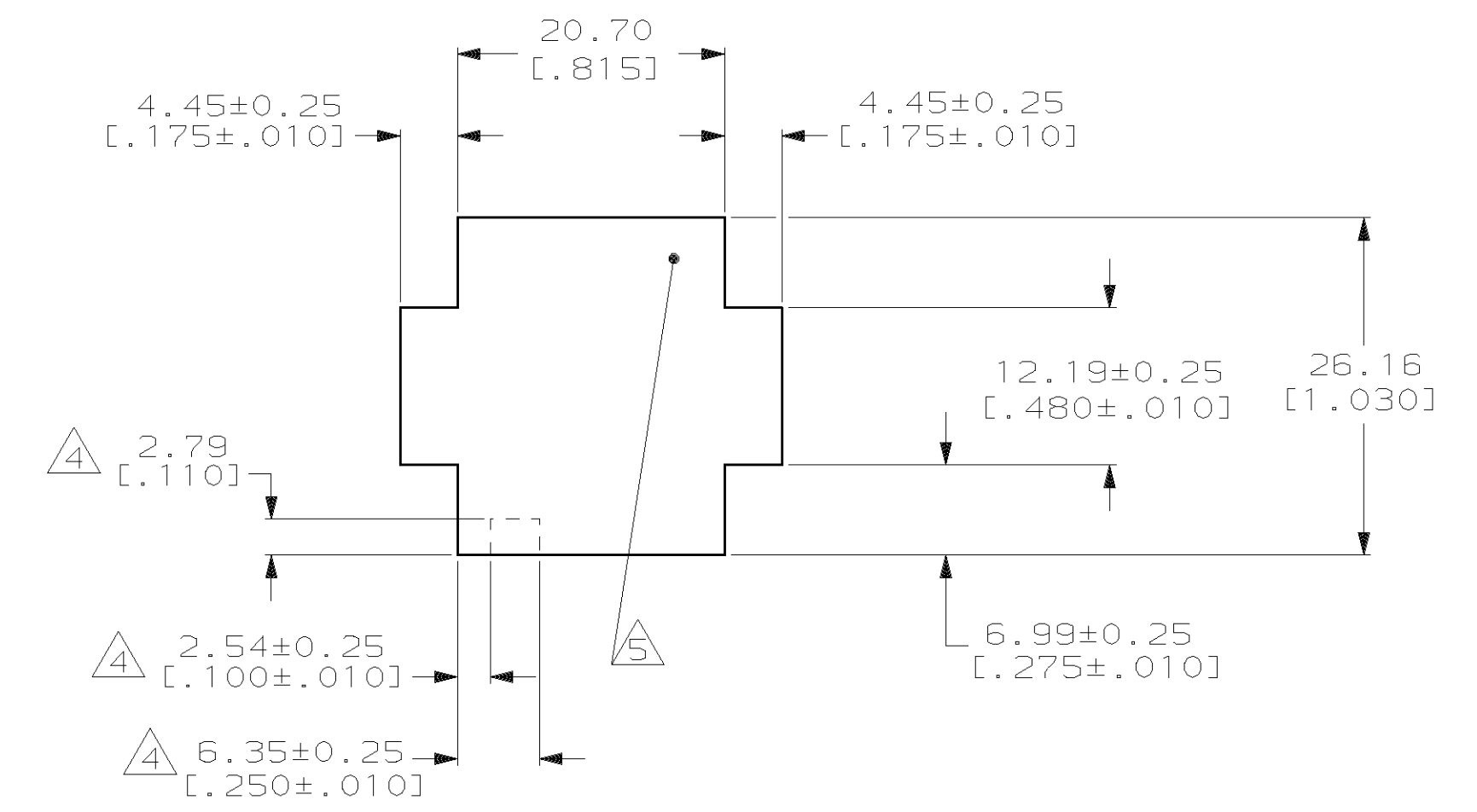

RECOMMENDED PANEL CUTOUT
 (HOUSING ENTRY SIDE)
 SCALE 2:1
 2 3

770053-1
 PART NUMBER



DO NOT SCALE PRINT. UNLESS SPECIFIED DIMENSIONS IN INCHES TOLERANCES ON:		DR 1-15-92 K. SALMON		AMP INCORPORATED Harrisburg, Pa. 17105	
2 PLC DEC ±		CHK 1-15-92 R. SWING		NAME	
3 PLC DEC ± 0.13 [.005]		APPD 1-16-92 M. TRULL		CAP FRONT, 9 CIRCUIT, UNIVERSAL MATE-N-LOK™ II	
ANGLES ±		APPD 1-16-92 M. TRULL			
MATERIAL NYLON, UL94V-0,		PRODUCT SPEC		SIZE D 00779	
FINISH		APPLICATION SPEC		DRAWING NO 770053	
WEIGHT		SCALE 5:1		SHEET 1 OF 1	